



(19) **United States**

(12) **Patent Application Publication**
Bishel

(10) **Pub. No.: US 2018/0148310 A1**

(43) **Pub. Date: May 31, 2018**

(54) **MOTORIZED LIQUID DISPENSER**

(71) Applicant: **Richard A. Bishel**, Beaverton, OR (US)

(72) Inventor: **Richard A. Bishel**, Beaverton, OR (US)

(21) Appl. No.: **15/860,188**

(22) Filed: **Jan. 2, 2018**

Related U.S. Application Data

(63) Continuation of application No. 14/397,089, filed on Oct. 24, 2014, now Pat. No. 9,856,128.

Publication Classification

(51) **Int. Cl.**
B67D 3/00 (2006.01)
A47G 23/02 (2006.01)
G01N 33/14 (2006.01)
G01F 13/00 (2006.01)

(52) **U.S. Cl.**

CPC **B67D 3/0051** (2013.01); **G01F 13/006** (2013.01); **G01N 33/146** (2013.01); **A47G 23/0241** (2013.01)

(57) **ABSTRACT**

A beverage dispenser comprises a bottle holder, a motor, and a controller. The bottle holder is configured to hold a bottle of a liquid beverage. The motor is connected to the bottle holder and configured to move the bottle holder in an angular movement to bring the bottle into a pouring position. The controller is configured to control the bottle holder via the motor in a set pattern to dispense a portion of the liquid beverage from the bottle into a serving receptacle. The liquid beverage may be wine, and the serving receptacle may be a wine glass. The liquid beverage may be liquor, and the serving receptacle may be a shot glass. The portion of the liquid may be an amount of liquid to fill the receptacle to a designated level. The portion of the liquid beverage is less than the entire capacity of the bottle.

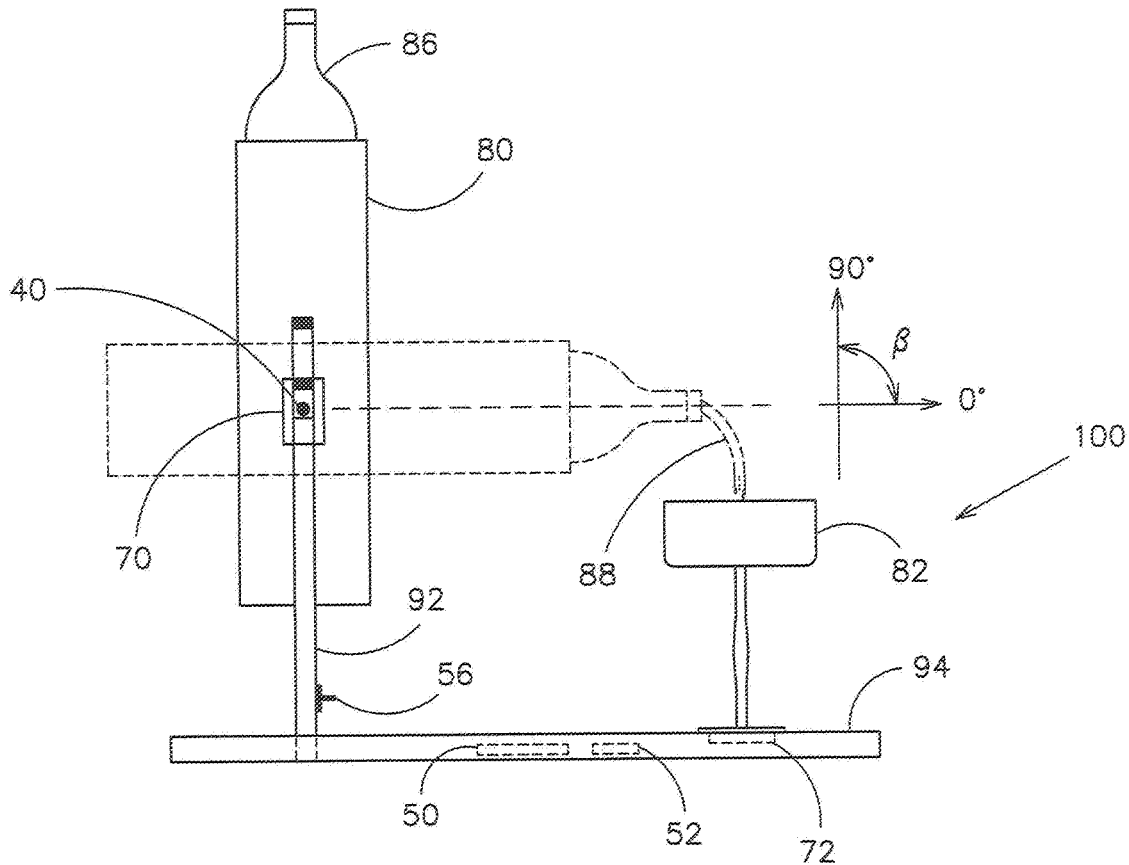

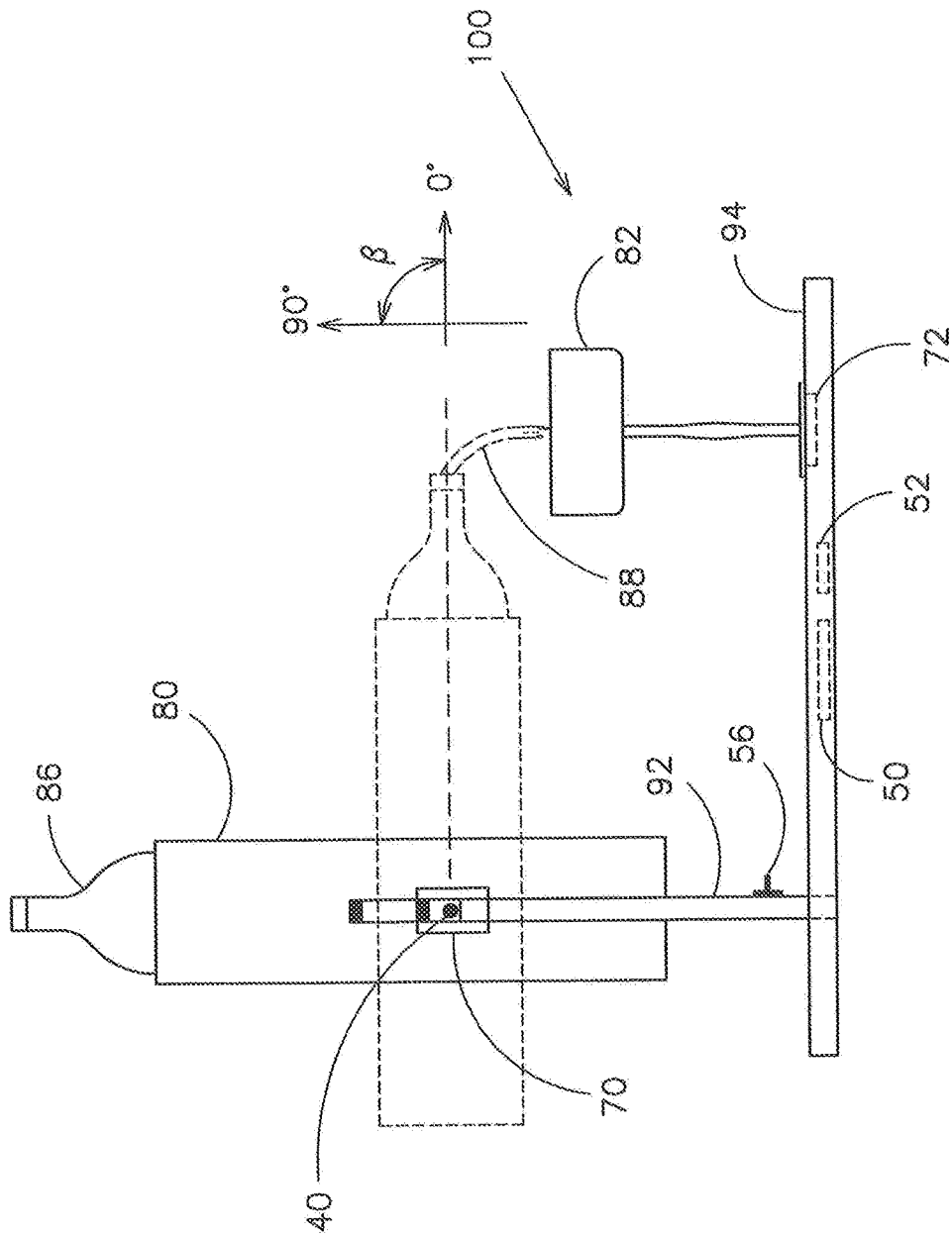

FIG. 1

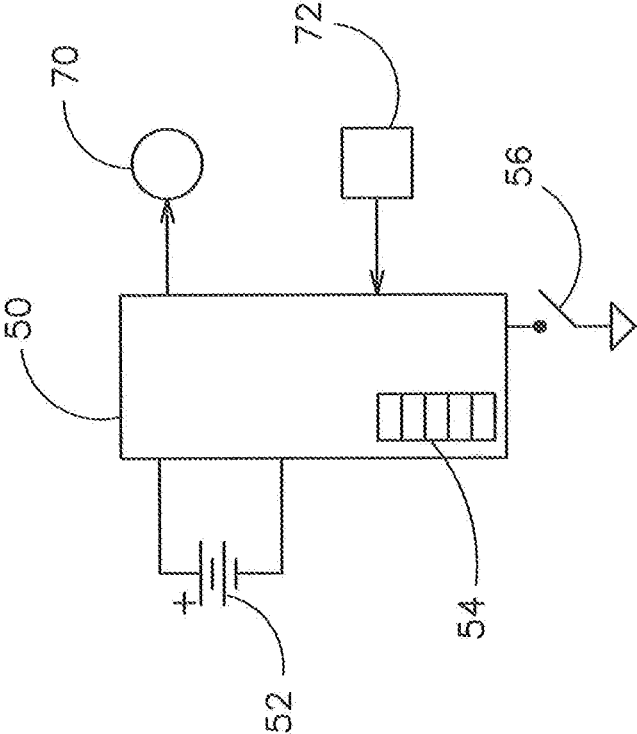

FIG. 2

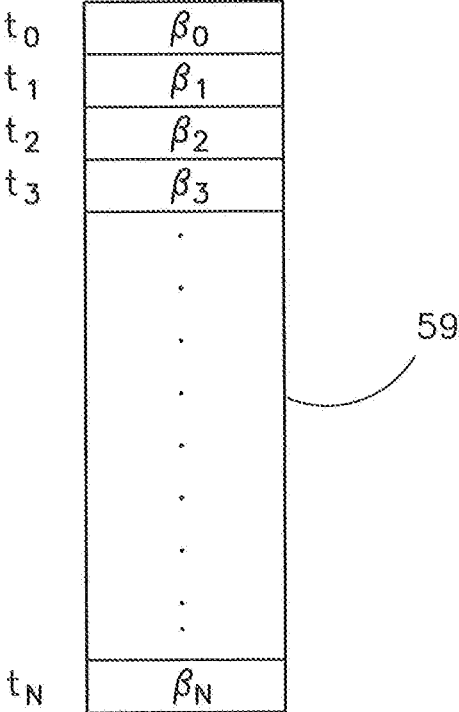

FIG. 3

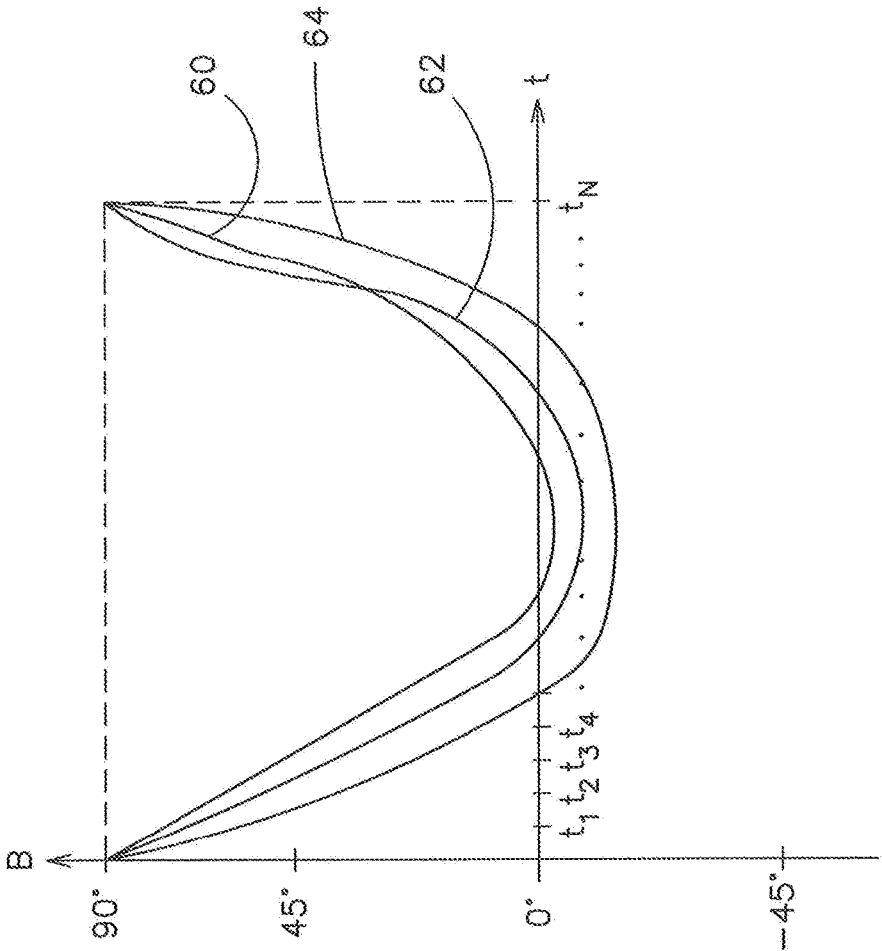

FIG. 4

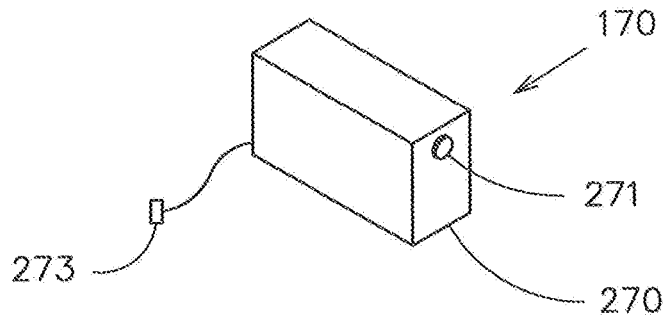

FIG. 5A

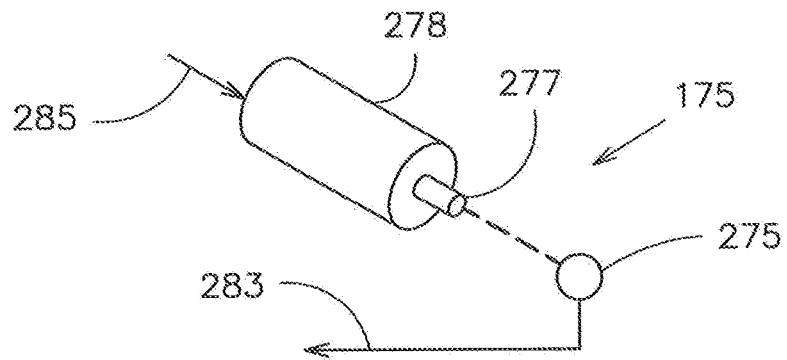

FIG. 5B

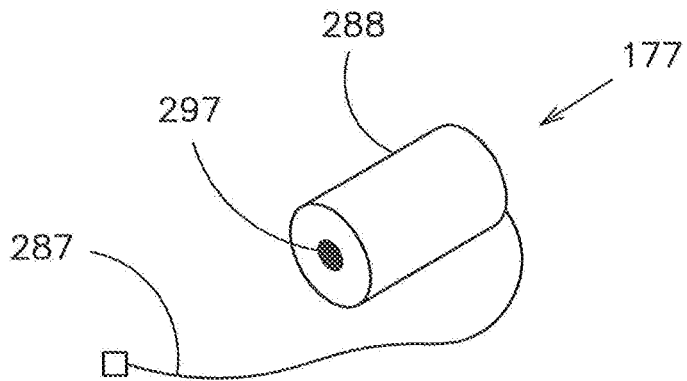

FIG. 5C

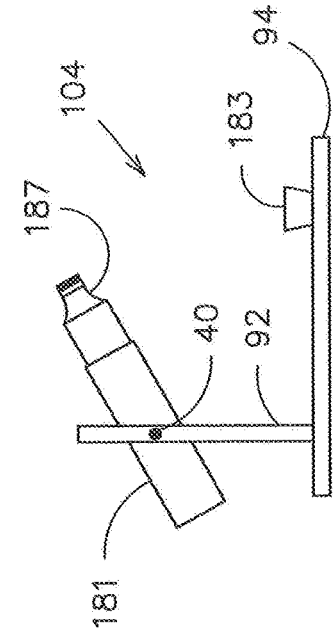

FIG. 6A

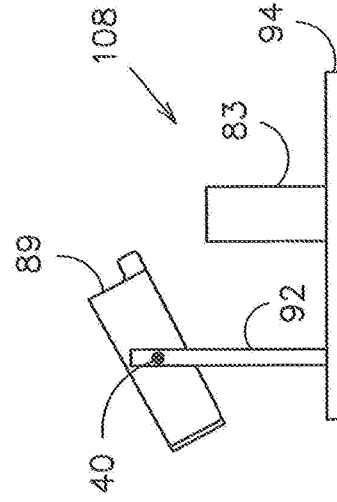

FIG. 6B

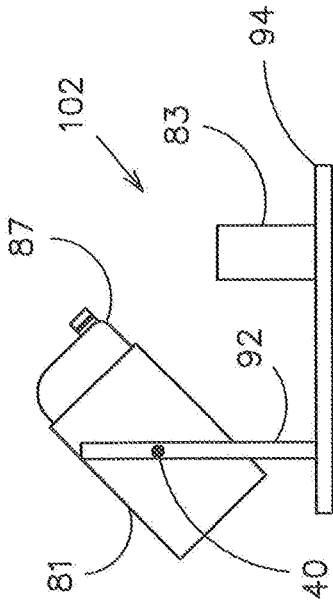

FIG. 6C

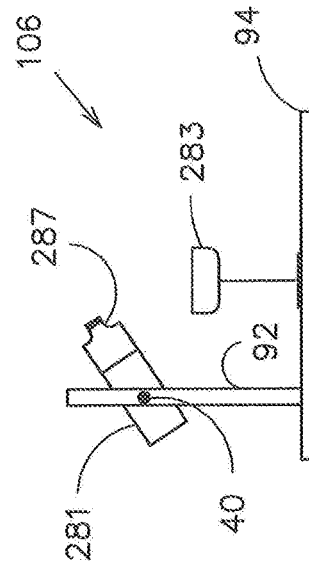

FIG. 6D

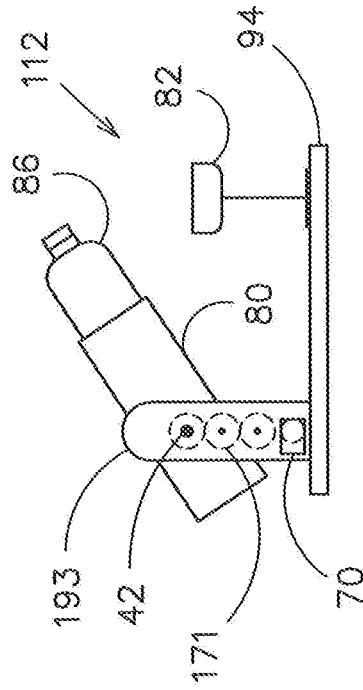

FIG. 7B

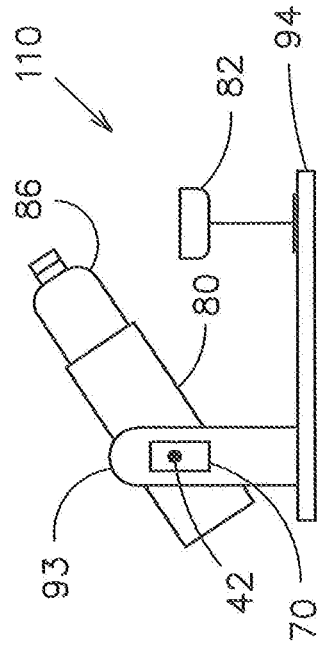

FIG. 7A

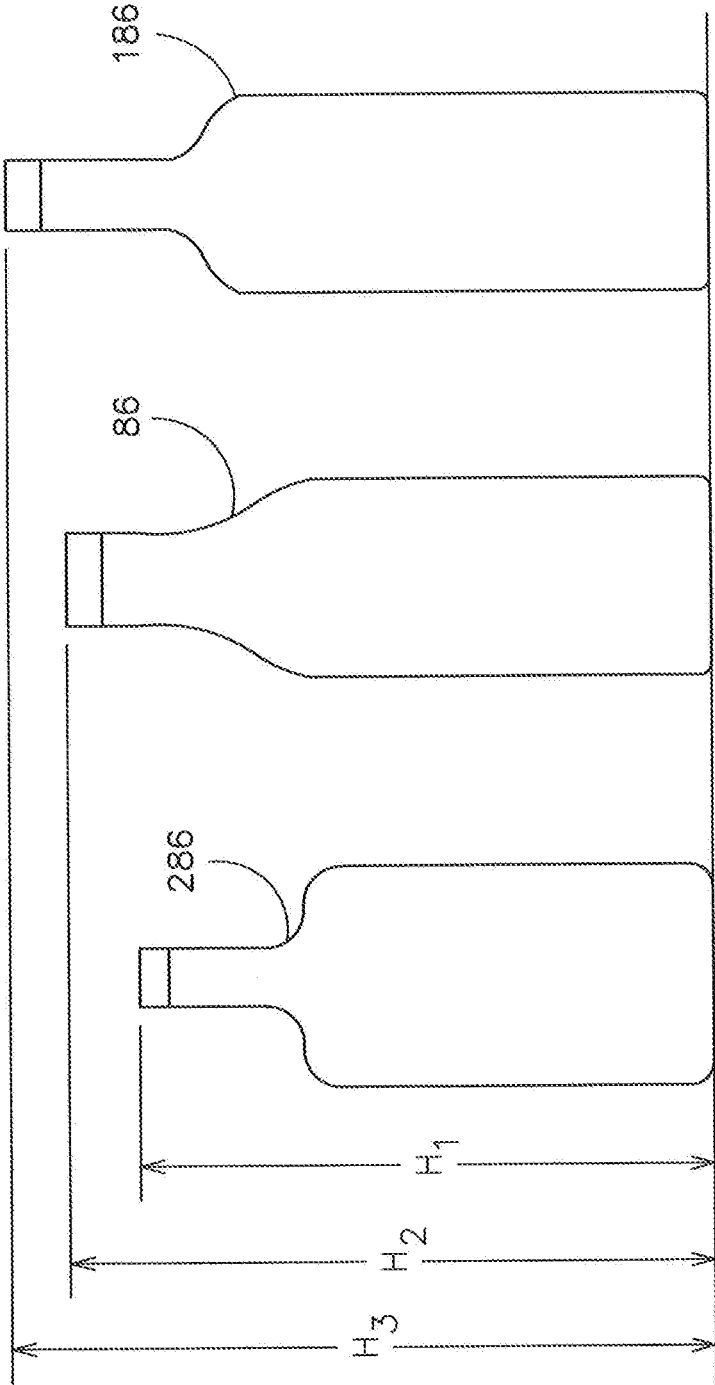

FIG. 8

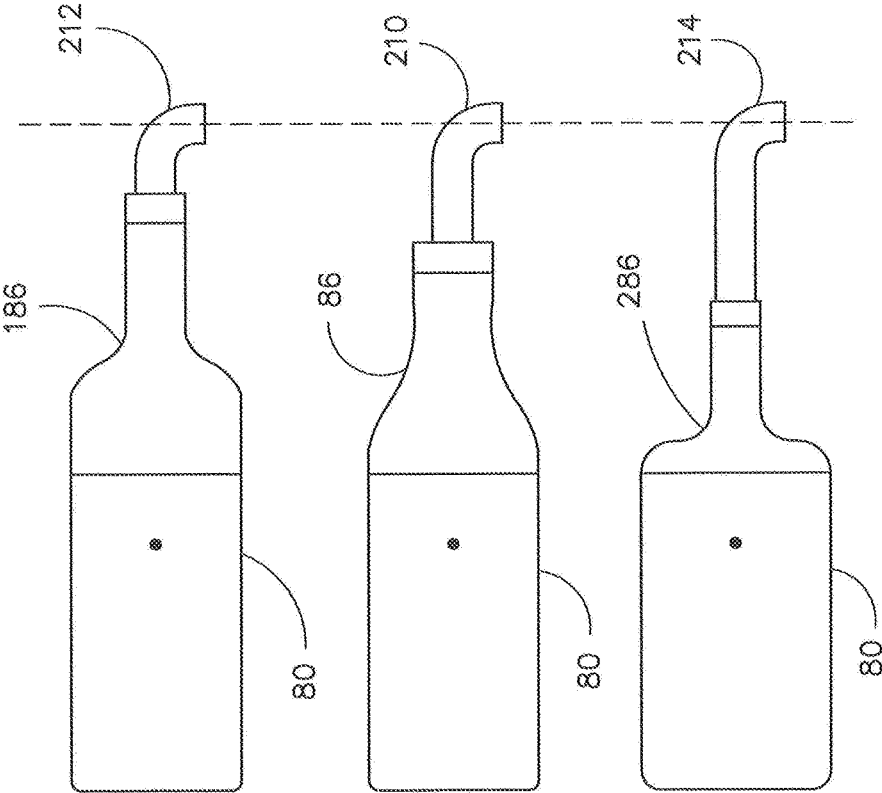

FIG. 9

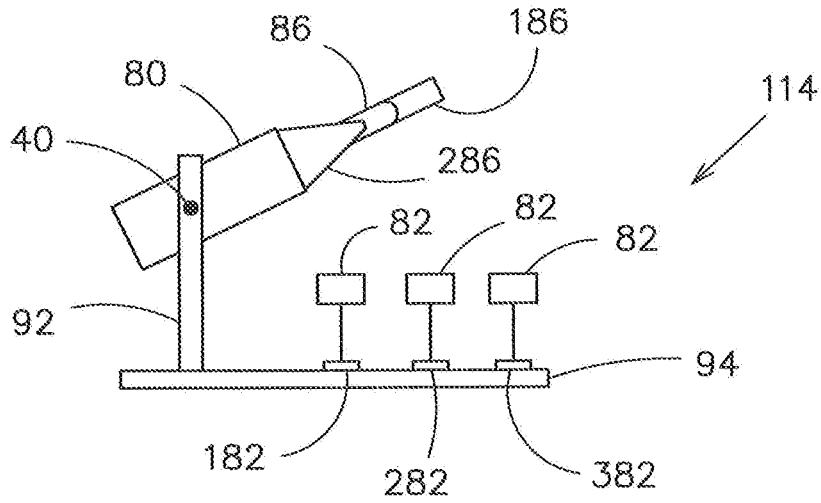

FIG. 10A

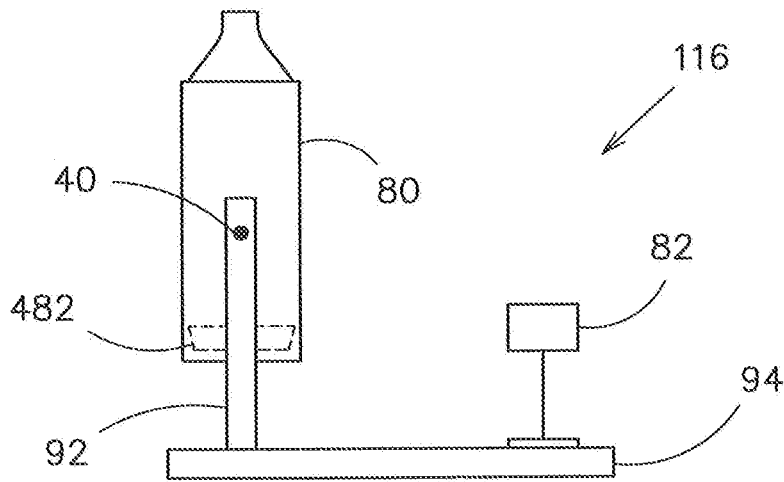

FIG. 10B

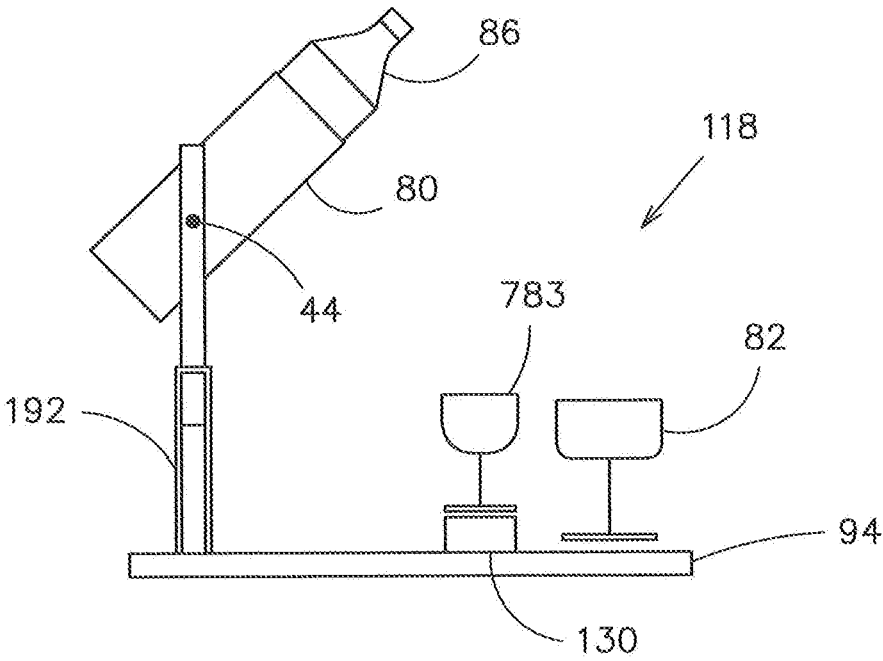

FIG. 11

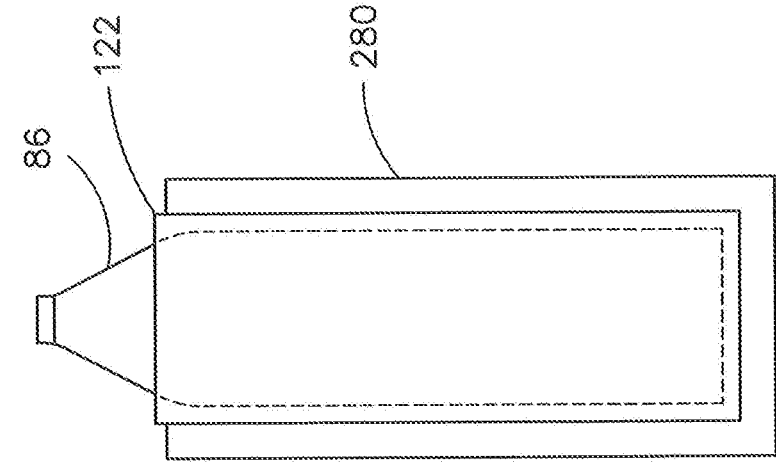

FIG. 12A

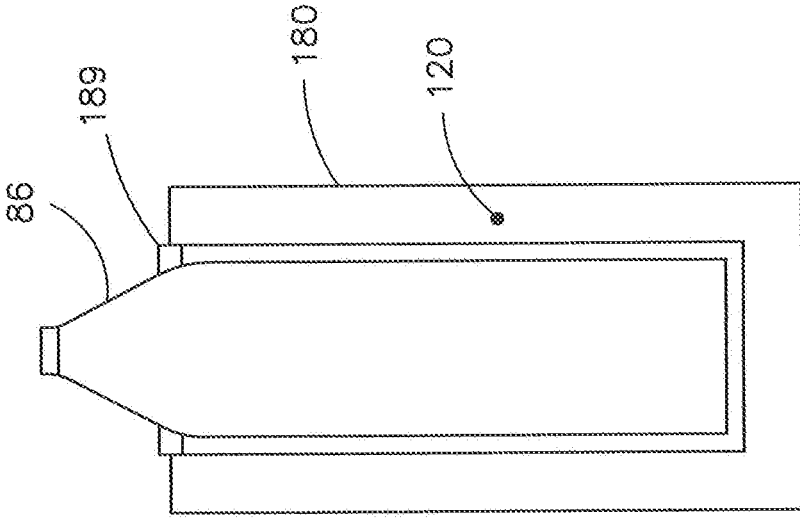

FIG. 12B

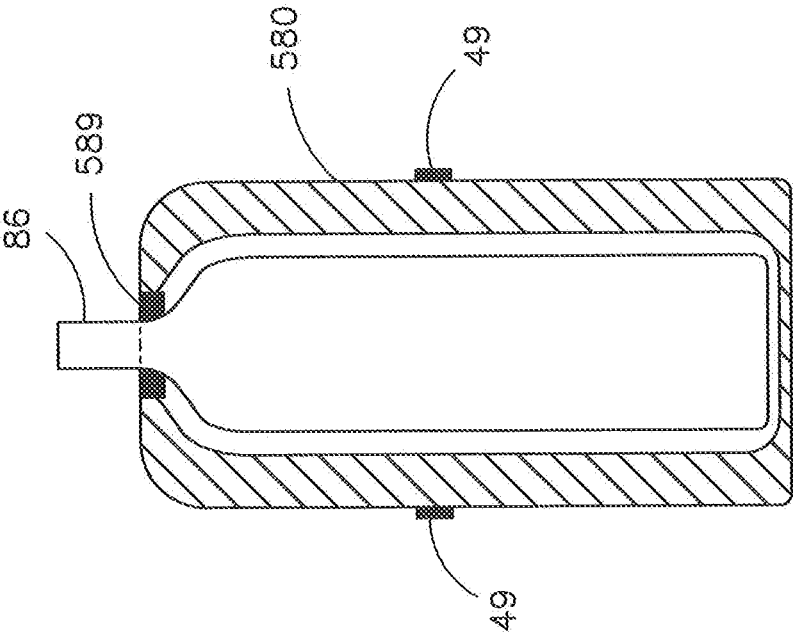

FIG. 12D

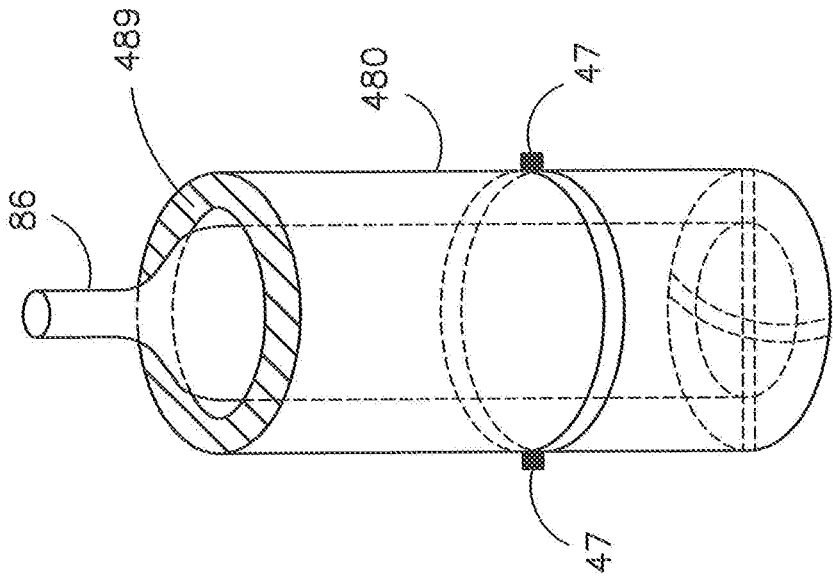

FIG. 12C

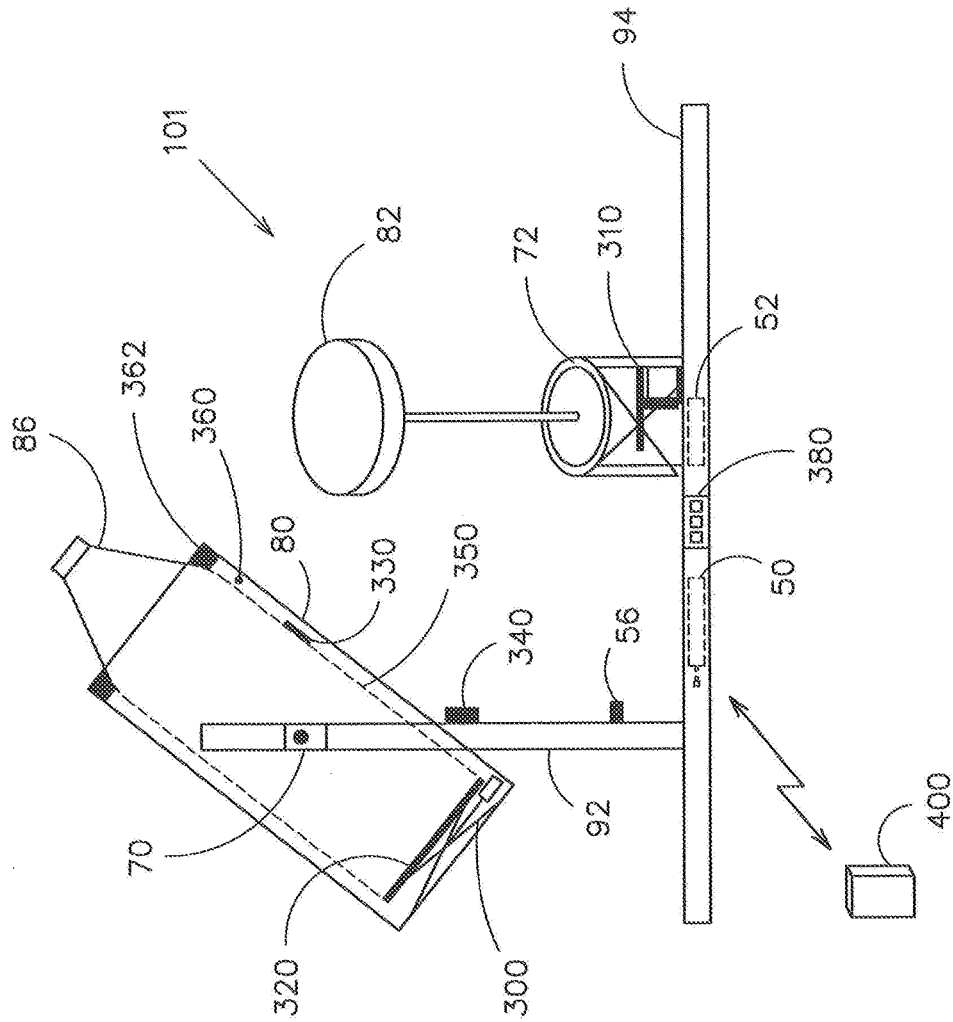

FIG. 13

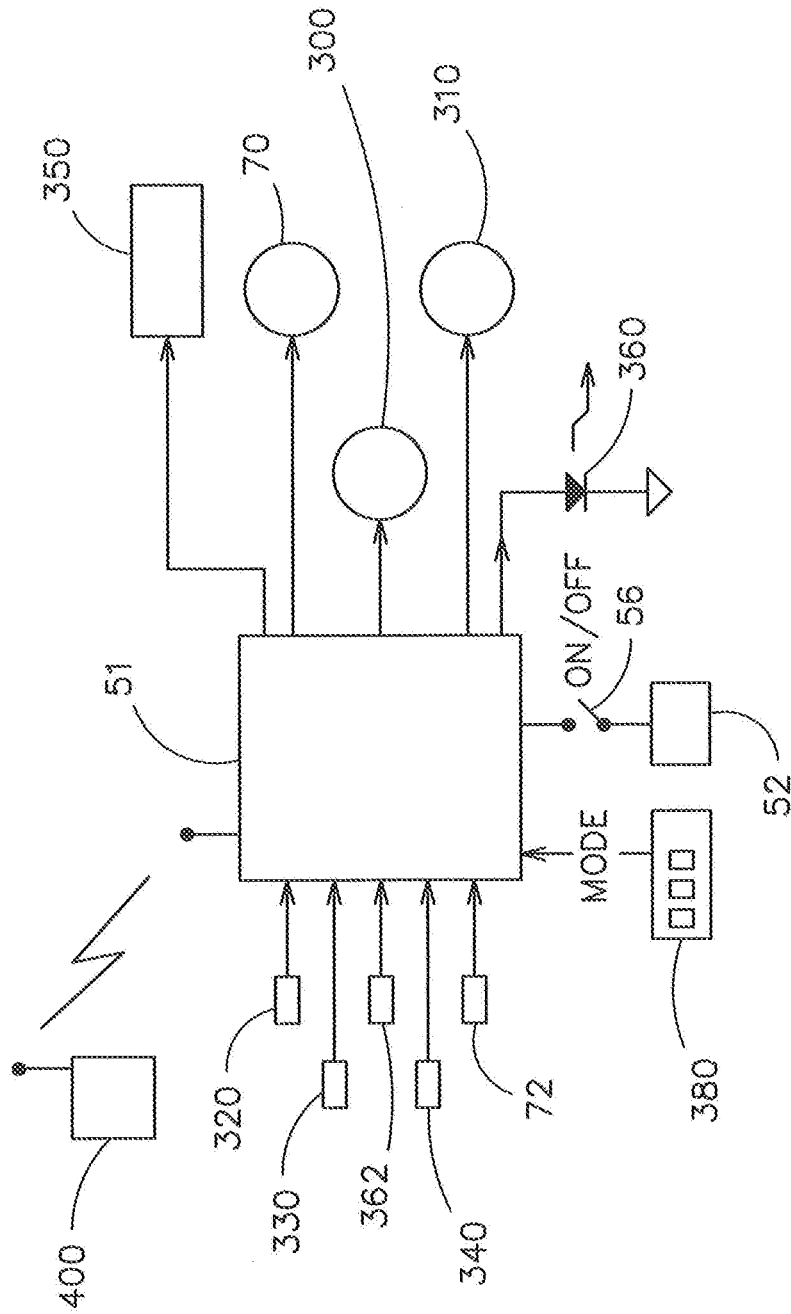

FIG. 14

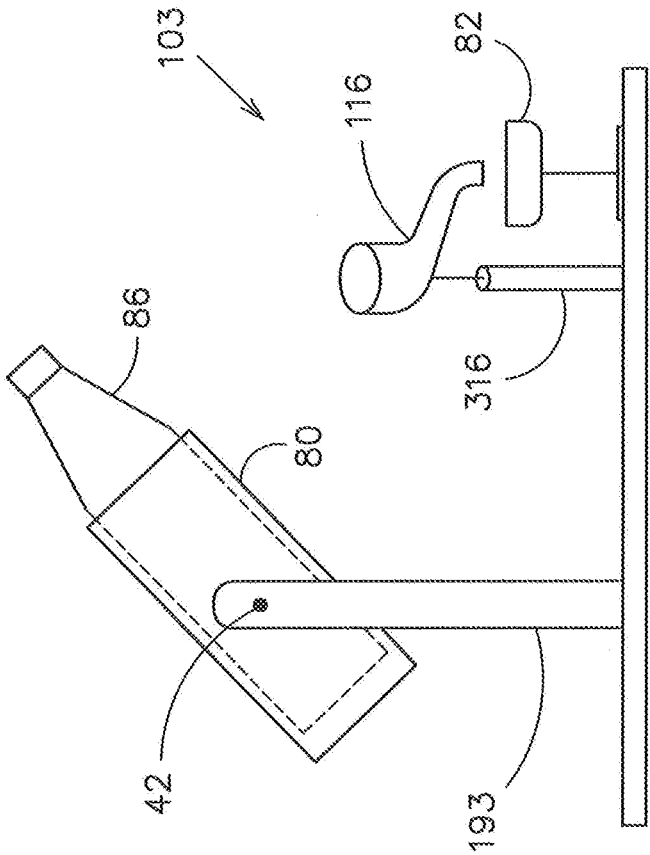

FIG. 15

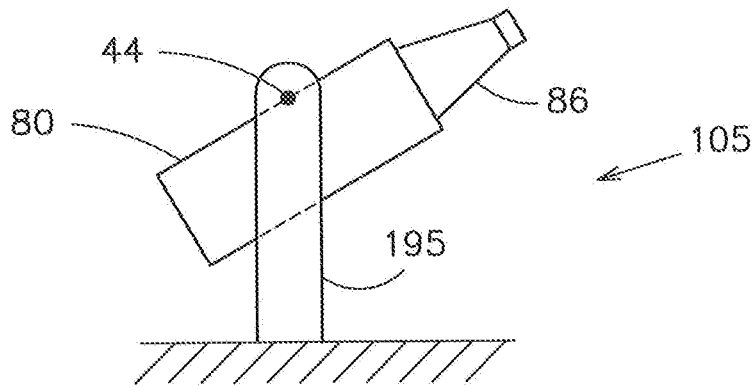

FIG. 16A

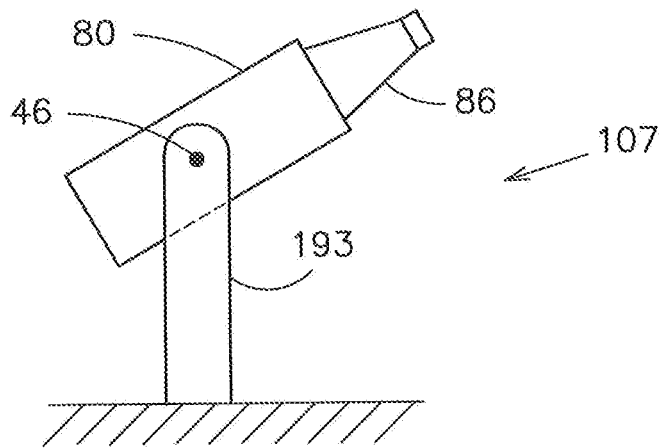

FIG. 16B

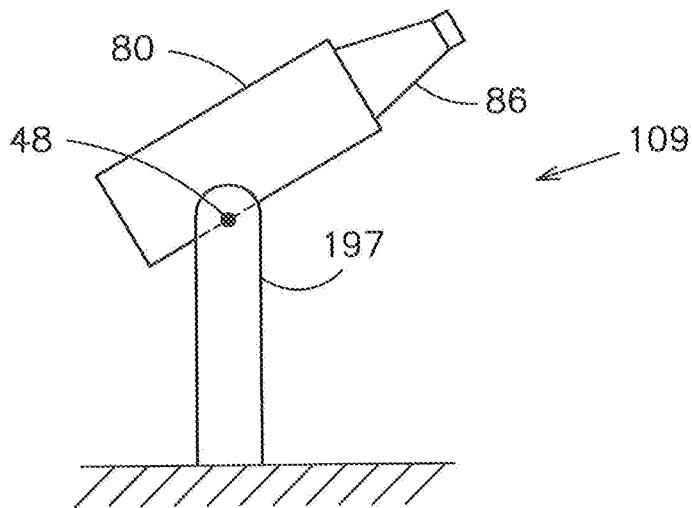

FIG. 16C

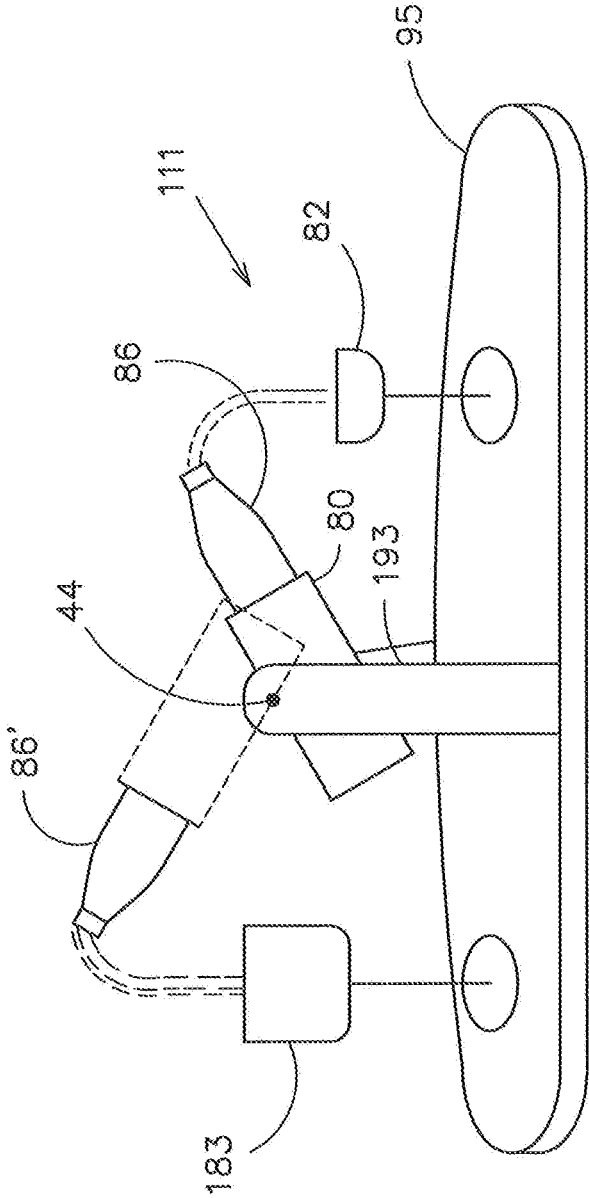

FIG. 17

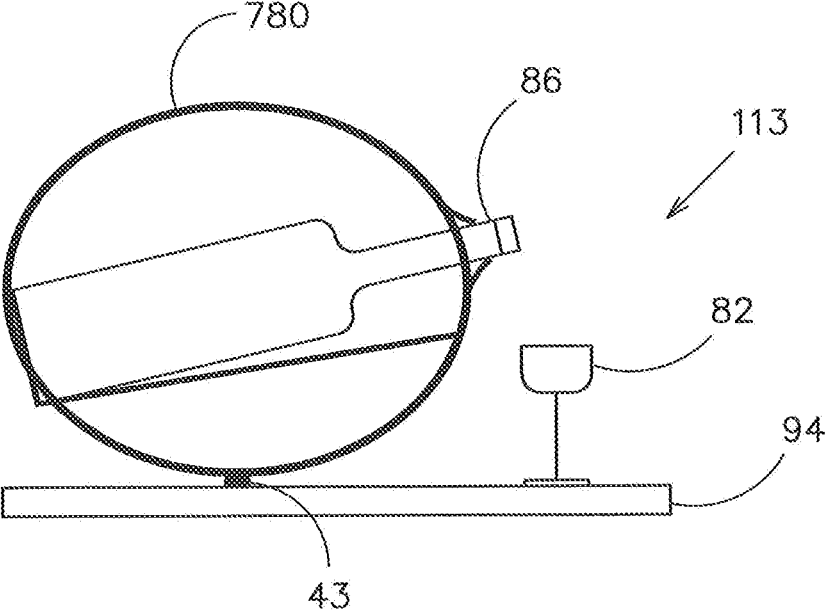

FIG. 18A

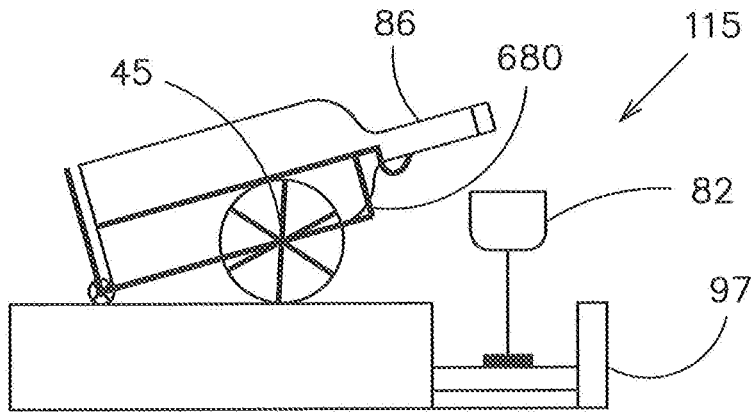

FIG. 18B

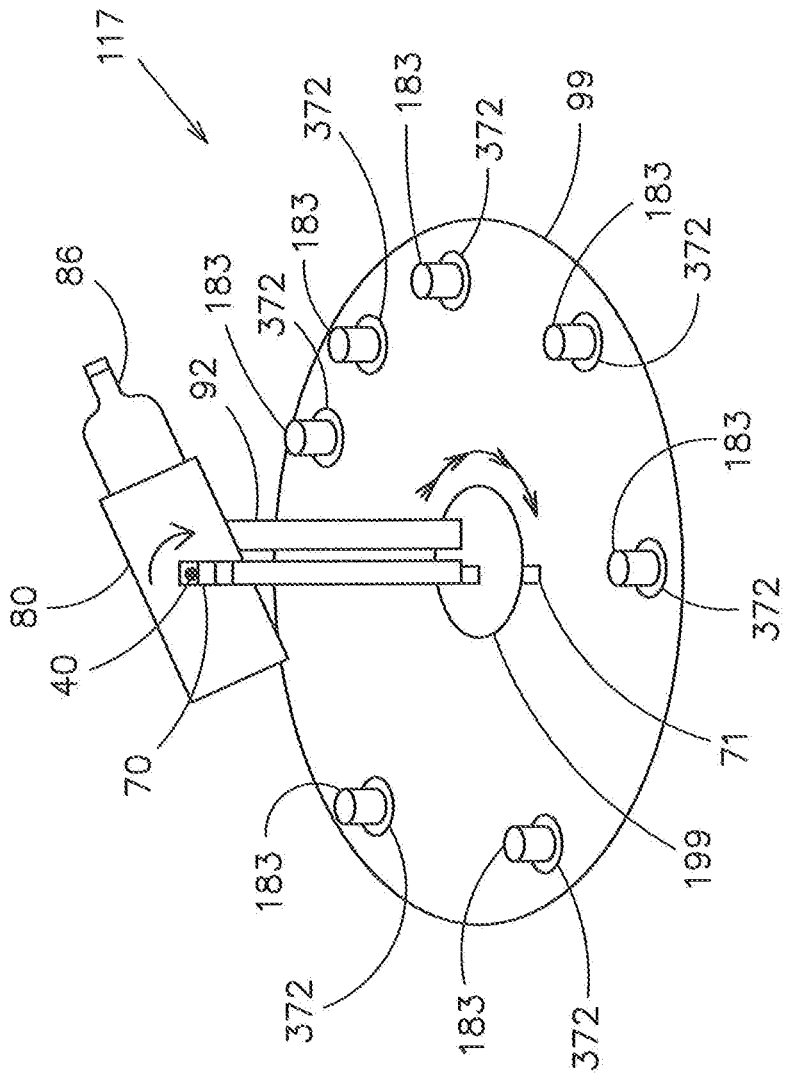

FIG. 19

MOTORIZED LIQUID DISPENSER

RELATED APPLICATIONS

[0001] This application is a continuation of the U.S. non-provisional patent application Ser. No. 14/397,089 filed Oct. 24, 2014 which claims the benefit to International PCT/US2013/038297/filed on Apr. 25, 2013 which claims the benefit of the provisional patent application No. 61/687,530 filed on Apr. 25, 2012, which are all hereby incorporated by reference herein in its entirety.

TECHNICAL FIELD

[0002] This disclosure relates generally to automatically or semi-automatically dispensing liquid from one container to another. More particularly, this disclosure related to an apparatus for automatically or semi-automatically dispensing a serving of a beverage from a container to a serving receptacle using an electric motor.

BACKGROUND INFORMATION

[0003] Pivotal supports have been used for many years to facilitate dispensing liquid from containers, from very small bottles of wine and distilled liquors as disclosed in U.S. Pat. No. 3,868,047 by Bersano, to large barrels of gasoline or oil as disclosed in U.S. Pat. No. 1,755,745 by Parr.

[0004] Prior art in dispensing small bottles is in the area for decanting of wines such as the manual process using a hand crank and pulleys, gears, or friction as disclosed in U.S. Pat. No. 3,868,047 by Bersano, or serving wines using a knob on the pivotal device disclosed in U.S. Pat. No. 6,889,945B2 by McCall. Both methods rely on the individual or server to pour the proper portion of liquid into the glass or container. Wiemholt discloses in U.S. Pat. No. 7,708,241 B2 automating the wine decanting process using a tilting process where the entire bottle is dispensed into a container.

[0005] There is also prior art using pumps such as disclosed in U.S. Pat. No. 6,435,421 issued to Morrison, or pressurized gas disclosed in U.S. Pat. No. 5,139,179 by Cecil. Additionally, there are many gravity-fed systems, where the bottle is placed upside down with the opening on the bottom and a manual valve controls the liquid. Automating the process is disclosed in U.S. Pat. No. 3,930,598 by Slagle.

SUMMARY OF THE DISCLOSURE

[0006] This disclosure relates to an apparatus for dispensing liquid from one container to another automatically. The liquid may be a consumable beverage, such as, for example, wine, water, juice, milk, beer, nectar, syrup, honey, soda, liquor, or the like, or mixtures of the foregoing.

[0007] According to one embodiment, a beverage dispenser comprises a bottle holder, a motor, and a controller. The bottle holder is configured to hold a bottle of a liquid beverage. The motor is connected to the bottle holder and configured to move the bottle holder in an angular movement to bring the bottle into a pouring position. The controller is configured to control the bottle holder via the motor in a set pattern to dispense a portion of the liquid beverage from the bottle into a serving receptacle.

[0008] Some optional aspects of this embodiment include the following. The liquid beverage may be wine, and the

serving receptacle may be a wine glass. The liquid beverage may be liquor, and the serving receptacle may be a shot glass. The bottle holder may be a container, which may be insulated. Alternatively, the bottle holder may be a wired cage. The motor be an electric motor. The controller may be selected from the group consisting of, for example, a computer, a microcontroller, and control circuitry. The set pattern may comprise angular positions of the bottle holder over time. The portion of the liquid may be an amount of liquid to fill the receptacle to a designated level. The portion of the liquid beverage is less than the entire capacity of the bottle. The beverage dispenser may further comprise a temperature sensor configured to monitor the temperature of the bottle.

[0009] Optionally, the beverage dispenser may further comprise a sensor configured to detect presence of the receptacle in a position to accept the beverage poured from the bottle, and the controller may be further configured to dispense a portion of the beverage from the bottle into the receptacle when the receptacle is detected via the sensor. The sensor may be selected from a group consisting of, for example, a weight sensor, a switch, a photo detector sensor, a motion sensor, a distance sensor, and a force sensor.

[0010] Optionally, the beverage dispenser may further comprise a wireless receiver configured to accept signals from a remote device, and the controller may be connected to the wireless receiver to accept a command from the remote device. The remote device may be selected from a group consisting of, for example, a handheld computer, a tablet, or a smart phone. The command may be a command to dispense a serving of the beverage into the serving receptacle.

[0011] Optionally, the beverage dispenser may further comprise a movable platform having a plurality of positions for a respective plurality of serving receptacles, and a motor connected to the movable platform and configured to move the movable platform to position each of the plurality of serving receptacles into a position to accept the a portion of the beverage poured from the bottle. The controller may be connected to the motor and further configured to move the movable platform to position each of the plurality of serving receptacles into a position to accept a portion of the beverage poured from the bottle. The movable platform may be a turntable.

[0012] According to another embodiment, a method comprises mechanically accepting and holding a bottle containing a beverage, and automatically or semi-automatically moving the bottle in an angular movement from a first position to a second position, wherein the first position is a position maintaining the beverage within the bottle, and the second position is a pouring position to cause a portion of the beverage to pour into a serving receptacle.

[0013] Optionally, the beverage may be wine, and the serving receptacle may be a wine glass. Alternatively, the beverage may be liquor, and the serving receptacle may be a shot glass. The step of moving the bottle may comprise moving the bottle by a predetermined angle over a predetermined time. The portion of the beverage may be an amount to fill the serving receptacle to a designated level. The method may further comprise sensing presence of the receptacle in a position to accept the beverage poured from the bottle, and the moving step may be performed in response to sensing presence of the receptacle in a position to accept the beverage poured from the bottle. The method

may further comprise receiving a wireless signal from a remote device, and the moving step may be performed in response to receipt of the wireless signal. The remote device may be selected from a group consisting of, for example, a handheld computer, a tablet, or a smart phone. The method may further comprise monitoring the temperature of the bottle. The method may further comprise automatically or semi-automatically moving a plurality of serving receptacles into position to accept a portion of the beverage poured from the bottle. The portion of the beverage is less than the entire capacity of the bottle.

[0014] According to yet another embodiment, a beverage pouring apparatus comprises means for accepting and holding a bottle containing a beverage, and means for at least semi-automatically moving the bottle in an angular movement from a first position to a second position, wherein the first position is a position maintaining the beverage within the bottle, and the second position is a pouring position to cause a portion of the beverage to pour into a serving receptacle. The means for accepting and holding a bottle containing a beverage may comprise a container, frame, or any other mechanism. The means for at least semi-automatically moving the bottle may comprise an electric or non-electric motor in combination with a controller, such as computer, microcontroller, or circuitry.

BRIEF DESCRIPTION OF THE DRAWINGS

[0015] FIG. 1 is a side view of one embodiment of the apparatus showing the pouring action.

[0016] FIG. 2 is a block diagram of a controller circuit.

[0017] FIG. 3 is a programmed sequence showing time and corresponding angular positions.

[0018] FIG. 4 is a set of graphs of the programmed sequence with angular positions vs. time.

[0019] FIG. 5A is an isometric view of a hobby servo motor.

[0020] FIG. 5B is an isometric view of a motor control system.

[0021] FIG. 5C is an isometric view of a stepper motor.

[0022] FIG. 6A is a side view of another embodiment of the apparatus with a gallon container.

[0023] FIG. 6B is a side view of another embodiment of the apparatus with a long bottle.

[0024] FIG. 6C is a side view of another embodiment of the apparatus with a short bottle.

[0025] FIG. 6D is a side view of another embodiment of the apparatus with a bottle and container as one unit.

[0026] FIG. 7A is a side view of another embodiment of the apparatus with brackets holding the container.

[0027] FIG. 7B is a side view of another embodiment of the apparatus with gears moving the container.

[0028] FIG. 8 is a side view of different heights and sizes of bottles.

[0029] FIG. 9 is a side view of the different bottles with different length pouring spouts attached.

[0030] FIG. 10A is a side view of another embodiment of the apparatus showing different placements of the glass.

[0031] FIG. 10B is a side view of another embodiment of the apparatus illustrating an insert within the container.

[0032] FIG. 11 is a side view of another embodiment of the apparatus illustrating two methods for accommodating the different heights of glasses.

[0033] FIG. 12A is a side view of the container of the apparatus with a vacuum.

[0034] FIG. 12B is a side view of the container of the apparatus with an insulated jacket insert.

[0035] FIG. 12C is an isometric view of the container of the apparatus consisting of wired cage.

[0036] FIG. 12D is a top view of the container made as cradle.

[0037] FIG. 13 is a side view of another embodiment of the apparatus illustrating a number of features.

[0038] FIG. 14 is a block diagram of a circuit showing a number of attached items.

[0039] FIG. 15 is a side view of another embodiment of the apparatus using a funnel.

[0040] FIG. 16A is a side view of the container mounted at the top of the container.

[0041] FIG. 16B is a side view of the container mounted at the center of the container.

[0042] FIG. 16C is a side view of the container mounted at the bottom of the container.

[0043] FIG. 17 is a side view of another embodiment of the apparatus that allows for pouring different height glasses.

[0044] FIG. 18A is a side view of another embodiment of the apparatus that incorporate a wired cage as the container.

[0045] FIG. 18B is a side view of another embodiment of the apparatus that incorporate a wheel-type mechanism as the container to hold the bottle.

[0046] FIG. 19 is an isometric view of another embodiment of the apparatus that can pour the liquid into multiple glasses.

DETAILED DESCRIPTION OF EMBODIMENTS

[0047] With reference to the above-listed drawings, this section describes particular embodiments and their detailed construction and operation. The embodiments described herein are set forth by way of illustration only and not limitation. Those skilled in the art will recognize in light of the teachings herein that there are alternatives, variations and equivalents to the example embodiments described herein. For example, other embodiments are readily possible, variations can be made to the embodiments described herein, and there may be equivalents to the components, parts, or steps that make up the described embodiments.

[0048] For the sake of clarity and conciseness, certain aspects of components or steps of certain embodiments are presented without undue detail where such detail would be apparent to those skilled in the art in light of the teachings herein and/or where such detail would obfuscate an understanding of more pertinent aspects of the embodiments.

[0049] As one skilled in the art will appreciate in view of the teachings herein, certain embodiments may be capable of achieving certain advantages, including by way of example and not limitation one or more of the following: (1) Providing restaurants, bars, cocktail lounge businesses, and the like a device to automate the process to provide a proper portion of liquid to be poured without error from the servers and without pumps or turning bottles upside down; and (2) providing elderly, infirm, weak, handicapped, or incapacitated individuals a device for pouring a portion of a liquid from containers, especially larger containers such as half or full gallons of milk. These and other advantages of various embodiments will be apparent upon reading the following.

[0050] Before proceeding with a detailed description of the illustrated embodiments, the following is provided as an overview.

[0051] A liquid dispenser having a receptacle or other holder for a bottle of liquid can rotate the receptacle. The receptacle may be connected to a motor, which may be electric, so that the motor can rotate the receptacle and therefore, the bottle of liquid. A controller may be programmed or otherwise configured to control the motor in a set sequence or pattern to dispense a portion of the liquid from the bottle. The bottle may be rotated to pour the liquid into a glass or other container. Furthermore, the sequence can be initiated via a sensor which detects the presence of the glass.

[0052] The motorized liquid dispenser contains a first container for holding the bottle of liquid and the motor may be connected to the first container to rotate or move the first container in an angular movement to bring the bottle from one position to a substantially different position to enable pouring of the liquid from the bottle. Furthermore, a controller may be programmed or otherwise configured to control the motor and in turn controls the angular position of the first container in a set pattern or sequence to dispense a portion of the liquid from the bottle in the first container to a second container such as a glass or cup. Furthermore, the initiation of this sequence may be from a sensor detecting the second container when placed on the apparatus.

[0053] The dispenser is well suited for an automated dispensation of wine using a container to hold the wine bottle. An electric motor may be connected to the container to move the container and therefore the wine bottle in an angular motion to a pouring position. A controller may be programmed or otherwise configured to control the electric motor in a set pattern to dispense a portion of the wine in the bottle to the glass. Furthermore, the initiation of the sequence may be from a sensor that detects the glass placement.

[0054] Referring to the drawings, wherein like referenced numerals represent like parts throughout the various drawing figures, reference numeral **80** is directed to the container for holding the bottle.

[0055] FIG. 1 shows one embodiment **100** which dispenses a portion of the liquid into bottle **86** to the glass **82** automatically as soon as glass **82** is placed on the sensor **72**. In particular, the bottle **86** of liquid is placed in the container **80**. The bottle **86** may be held in place by the friction of the inside of the container or bottle holder **80** or sleeve (not shown) on the bottle **86**. An electric motor **70**, in particular, a servo motor, a hobby servo motor, a position-controlled motor, a stepper motor, or a motor-controlled system, controls an angular position β , and an angular rate of change of the container **80** about the pivot point **40** on the vertical rods **92** (not shown is the second rod on the opposite side). The vertical rods **92** are supported by a base **94**. Inside the base **94** is the controller **50** and a power source **52**, which may be batteries, re-chargeable batteries, or an attachment to an external power supply. The controller **50**, which is shown in FIG. 2 along with the power source **52** in the form of batteries and an on/off switch **56**, takes input from the glass sensor **72**, which detects the glass **82** when placed on the base **94** and controls the electric motor **70** according to a stored profile **54** in FIG. 3. The glass sensor **72** may be, for example, a weight sensor, a switch, a photodetector sensor, a motion sensor, a distance sensor, or a force sensor. The controller **50** can be, for example, a microcontroller, a small

computer, or dedicated control circuitry. The stored profile **54** contains the angular positions β at various time intervals.

[0056] FIG. 3 shows, at time t_0 , the angular position β_0 is stored; at time t_1 , the angular position β_1 is stored; and so on. This profile continues until the final time t_N and the angular position β_N are stored. The stored profile **54** may be derived from a recorded position of a person pouring the liquid from the bottle to the glass. The stored profile is a replica of the recorded position and the controller **50** plays back the profile as if it was the original profile.

[0057] FIG. 4 shows profiles for a particular bottle **86** being poured into several glasses. Profile **60** represents the recording of the first time the bottle **86** is poured into the glass **82**. Profile **62** is the next pour for the second glass, profile **64** would be the third glass, and so on. As shown in FIG. 4, the container **80**, and therefore the bottle **86** is in an upright position (vertical position), $\beta=90$ degrees referring to the small graph in FIG. 1. While the liquid is dispensing into the glass **82**, the container **80** and the bottle **86** are near or below horizontal position, $\beta=0$ degrees or less to disperse the liquid from the bottle **86**. After pouring a portion of the liquid from the bottle **86**, the container **80** and bottle return to the vertical position, $\beta=90$ degrees or some other inclined position sufficiently upright to hold the remaining contents of the bottle **86**.

[0058] FIGS. 5A-C show several different types of electric motors that can provide precision pours in combination with the controller **50**. FIG. 5A illustrates of one type of motor **170**, called a hobby servo motor **270**, with an output gear **271**, and a 3-pin wire input **273**. The wire input provides power, ground, and a command signal. Servo motors of this type provide different torque and speed ratings for different applications. For pouring a glass of wine from a 750 ml wine bottle or portion of the wine from the 750 ml wine bottle in the previously described in FIG. 1, a typical torque rating of 80 oz-in and a speed rating of 0.2 seconds/60 degrees would work fine for a motor **70**. For a gallon jug, a higher torque rating would be needed. FIG. 5B illustrates another type of motor **175**, called a servo motor controlled system which contains an electric motor **278**, a output gear **277**, and a feedback sensor **275** such as a potentiometer. The electric motor **278** is driven from a current driver (not shown) via electric connection **285** from the controller. The controller drives the motor output **277** to the proper angular position based off of information from the feedback sensor **275**. FIG. 5C illustrates another type of motor **177** called a stepper motor **288**, which requires a starting position and counts. The controller keeps track of the steps in the stepper motor unit. The output gear **297** would drive the angular motion, and the drive capability for the stepper motor **288** is from the wired connection **287**.

[0059] FIG. 6A-6D show different embodiments for different types of bottles. FIG. 6A illustrates embodiment **102** which dispenses liquid from the gallon jug **87** into a cup **83**. The controller and operation is similar to what has been described above but with a different stored profile. FIG. 6A shows the container **81** which holds a gallon container **87** which is controlled at pivot point **40**. The vertical rods **92** support the container **87** and the base **94** supports the rods **92** and the cup **83**.

[0060] FIG. 6B illustrates embodiment **104** in which the container **181** holds a long neck bottle **187**. In a similar manner, the vertical rod **92** holds the container about the

pivot point **40** along the rod axis. The electric motor (not shown in this figure) controls the angular position of the container **181** to dispense a small portion of the liquid from the bottle **187** into a short glass **183**. The precision pour would provide the correct portion of liquid typically used in a bar situation. The operation of dispensing the liquid is similar as described previously, but the stored profile would be different.

[0061] FIG. 6C illustrates an embodiment **106** holding a short bottle **287** with container **281**. The short bottle could be a beverage bottle. FIG. 6D shows the container and bottle **89** as the same unit. In this embodiment **108**, one would add the liquid into the container **89** prior to dispensing.

[0062] FIG. 7A shows an embodiment **110** having a different mechanical mechanism for holding the container **80**. Instead of vertical rods, the container **80** pivots on two support brackets **93** and pivot point **42**, one on each side. The embodiment **110** contains the brackets **93** along with the electric motor **70**. The bottle **86**, glass **82**, and base **94** are the same as described previously. FIG. 7B shows the similar bracket **193** as in FIG. 7A but the electric motor **70** is mounted near the base **94** of the embodiment **112**. Gears **171**, inside the bracket **193**, control the container **80** about the pivot point **42** on the top of the bracket **193**.

[0063] FIG. 8 shows different lengths, H1, H2, and H3, of particular 750 ml wine bottles, **286**, **86**, and **186**, respectively. In order to accommodate these bottles without building a new fixture, the attachment pouring device with different lengths can accommodate the bottle length as shown in FIG. 9. The bottle **286** is the shortest one and uses the longest neck pourer **214**. The bottle **186** is the longest and uses the shortest pourer **212**. The standard length bottle **86** uses the standard pourer **210**.

[0064] Another method to accommodate the different length bottles **286**, **86**, and **186** is by leaving different pads **182**, **282**, and **382** on the base **94**, as shown in FIG. 10A. For short length bottles such as **286**, the pad **182** would allow the liquid from the bottle to be dispensed properly by having glass **82** on pad **182**. Likewise, bottle **86** would be dispensed properly in same type of glass **82** at pad **282** and bottle **186** would be dispensed properly in similar glass **82** on pad **382** as shown in FIG. 10A.

[0065] Another method to accommodate different length bottles is shown in FIG. 10B, wherein an embodiment **116** shows different inserts **482** that are used to accommodate the different length bottles in the container **80**.

[0066] To accommodate different glass heights, embodiment **118** shows two methods in FIG. 11 that can be used. Standard height glass **82** is at proper height for bottle **86** to pour the liquid. To accommodate glass **783**, one method would be to raise the glass **783** by an insert **130** on the base **94**. Another method would be to raise or lower the vertical rods **192** or axis point **44**, also shown in FIG. 11. Note that similar sized glasses within a certain range can be easily accommodated by the proper height of the axis point **44**. Beside glasses, one can pour into cups, smaller bottles, serving containers, shot glasses, or flasks.

[0067] Since the container would be on a table or counter, the liquid may cool or warm up based on the difference in bottle temperature versus room temperature. To minimize this effect, in the embodiments **100-118**, the container may contain a vacuum similar to thermos bottles or an insulated jacket. In FIG. 12A shows a container **180** containing a vacuum **120** to keep the temperature of the bottle **86** from

changing quickly. FIG. 12B shows container **280** with an insulated material **122**. FIG. 12C shows an isometric view of the container **480** made from a thick wired cage. The bottle **86** is placed within the wired cage **480** and a rubber or flexible material ring **489** secures the bottle **86** with the wired cage **480**. The pivot points **47** are shown on the middle section of the wired cage **480**. FIG. 12D shows a top view of the container **580** where the bottle **86** lies in the container like a cradle. A rubber or flexible material secures the bottle **86**. The pivot points **49** are shown on the container **580** where the unit is rotated.

[0068] FIG. 1 shows the basic concept of the embodiment **100**. FIG. 13 shows additional features that can be incorporated into an embodiment **101**. FIG. 13 shows another method to accommodate the glass **82** height by utilizing a scissor-type mechanism **310** to raise or lower the glass via an electric motor. Likewise, the different length bottles can be accommodated by scissor-type mechanism **300** which raises or lowers the bottle **86**. A weight sensor **320** can be used to detect the presence of the bottle **86** and the amount of liquid in the bottle **86**. In addition to the glass sensor **72**, another method for detecting the glass would be via a distance or object sensor **340**. The temperature sensor **330** measures the temperature of the liquid in bottle **86**. LEDs **360** may be mounted on the container **80** as shown in FIG. 13 or on the base **94** (not shown) or rod **92** (not shown). A keypad **380** is shown attached to the base **94** and the keypad **380** can select profiles, modes of operation, bottle types, or glass types. Also shown, a remote control device **400** can be a handheld computer, tablet, or smart phone or other smart device for controlling the operation wirelessly or for selecting similar functions as the keypad **380**, but remotely. FIG. 14 shows the block diagram of the some of the input and output devices that the controller **51** that can be implemented. Input devices, such as weight sensor **320**, temperature sensor **330**, bottle detector **362**, object sensor **340**, glass sensor **72**, keypad **380**, switch **56**, and remote control device **400** are shown in FIG. 14. The output devices can be motor to control the scissor-type mechanism **300**, an electric motor **70** to control the angle of the container **80**, electric motor to control the scissor-type mechanism **310**, an electric heater/cooler element **350**, and LEDs **360**.

[0069] FIG. 15 shows another embodiment **103** which uses an additional funnel **116** to bring the liquid from the bottle when poured via the controller/motor to the glass **82**. Different glasses can be accommodated by adjusting the height of the funnel via a mechanism **316**.

[0070] FIG. 16A-C shows three different embodiments **105**, **107**, and **109**, respectively, for different pivot locations. In FIG. 16A, an embodiment **105** contains a pivot point **44** that is located on top of the container with bracket **195**. In FIG. 16B, an embodiment **107** contains a pivot point **46** that is located in the center of the container with bracket **193** as shown previously. In FIG. 16C, an embodiment **109** contains a pivot point **48** that is located on the lower side of the container with bracket **197**. Another embodiment **111** shown in FIG. 17 illustrates how the pivot point **44** stays the same but the container **80** rotates from one side to pour the bottle **86** in a shorter glass **82** and on the other side as shown with bottle **86** into a taller glass **183**. The base plate **95** would be longer in this embodiment.

[0071] FIG. 18A and FIG. 18B shows other embodiments that utilize a different mechanism to hold the bottle instead of the vertical rods or bracket to hold the container. In FIG.

18A, embodiment **113** shows the bottle **86** is being held in a thick wired cage **780** and the pivot point **43** & motor combination is on the base **94** to rotate the wired cage. By rotating the wired cage and bottle, the liquid is poured into the glass **82** similarly as described previously. FIG. **18B** shows another embodiment **115** with the pivot point **45** positioned on the wheel carriage **680** which cradles the bottle **86**. The base **97** accommodates different glasses such as glass **82** by inserts or scissor-type mechanisms as previously described. In FIG. **18B**, the bottle is rotated with the wheel and therefore, the liquid from the bottle **86** is poured into the glass **82**.

[**0072**] FIG. **19** illustrates another embodiment **117** which provides for filling multiple glasses **183**. The container **80** is mounted on vertical rods **92** as described earlier but the vertical rods **92** are mounted on a rotating platform **199** installed on a round base **99**. The motor **71** rotates the rotating platform **199** to the proper glass position and the motor **70** controls the portion of liquid poured from the bottle **86**. With this embodiment, the container **80** does not need to return to the full upright position but to a position where no more liquid would be poured from the bottle **86**. This would expedite the filling of multiple glasses. FIG. **19** shows multiple shot glasses **183** on sensor pads **372** which detect the presence of each glass **183**. If the glass is not present, the apparatus would move onto the next glass that is present. Also, the platform where the glasses **183** are placed can rotate and the container **80** and vertical rods **92** are fixed in the round base **99**.

[**0073**] According to another embodiment, a beverage pouring apparatus comprises (1) means for accepting and holding a bottle containing a beverage and (2) means for at least semi-automatically moving the bottle in an angular movement from a first position to a second position, wherein the first position is a position maintaining the beverage within the bottle, and the second position is a pouring position to cause a portion of the beverage to pour into a serving receptacle.

[**0074**] The means for accepting and holding a bottle containing a beverage may be any one of the containers **80**, **81**, **89**, **180**, **181**, **280**, **281**, or **580**. Alternatively, the means for accepting and holding a bottle containing a beverage may be any one the frames **480** or **680**. Alternatively, the means for accepting and holding a bottle containing a beverage may be any equivalent of the foregoing.

[**0075**] The means for at least semi-automatically moving the bottle may be any one of these types of motors **70**, **170**, **175**, or **177**. Alternatively, other types of motors that not electrical can be used

[**0076**] The terms and descriptions used above are set forth by way of illustration only and are not meant as limitations. Those skilled in the art will recognize that many variations, enhancements and modifications of the concepts described herein are possible without departing from the underlying principles of the invention. For example, the subject matter disclosed in any sentence or paragraph herein can be combined with the subject matter of one or more of any other sentences or paragraphs herein as long as such combinations are not mutually exclusive or inoperable. The scope of the invention should be determined only by the following claims and their equivalents.

1. A beverage dispenser comprising:

a bottle holder configured to hold a bottle of a liquid beverage;

a motor connected to the bottle holder to cause the bottle holder to tilt;

a pivot point which is between the top and bottom of said bottle holder driven by the motor; and

a controller configured to automatically control the bottle holder via the motor to tilt by a predetermined angle for a predetermined time to bring the bottle into a pouring position to dispense a predetermined quantity of the liquid beverage by gravity from the bottle into a serving receptacle and to return the bottle to an upright position.

2. A beverage dispenser according to claim 1, wherein the liquid beverage is wine, and the serving receptacle is a wine glass.

3. A beverage dispenser according to claim 1, wherein the liquid beverage is wine, and the serving receptacle is a large container to receive the entire bottle of wine.

4. A beverage dispenser according to claim 1, wherein the bottle holder is a container.

5. A beverage dispenser according to claim 4, wherein the container is insulated.

6. A beverage dispenser according to claim 1, wherein the bottle holder is a wired cage.

7. A beverage dispenser according to claim 1, wherein the motor is an electric motor.

8. A beverage dispenser according to claim 1, wherein the controller is selected from the group consisting of a computer, a microcontroller, and control circuitry.

9. A beverage dispenser according to claim 1, wherein the serving of the liquid is an amount of liquid to fill the serving receptacle to a designated level.

10. A beverage dispenser according to claim 1, further comprising:

a sensor configured to detect presence of the receptacle in a position to accept the beverage poured from the bottle; and

wherein the controller is further programmed to dispense a serving of the beverage from the bottle into the serving receptacle when the receptacle is detected via the sensor.

11. A beverage dispenser according to claim 10, wherein the sensor is selected from a group consisting of a weight sensor, a switch, a photo detector sensor, a motion sensor, a distance sensor, and a force sensor.

12. A beverage dispenser according to claim 1, further comprising:

a wireless receiver configured to accept signals from a remote device, and wherein the controller is connected to the wireless receiver to accept a command from the remote device.

13. A beverage dispenser according to claim 12, wherein the remote device is selected from a group consisting of a handheld computer, a tablet, or a smart phone.

14. A beverage dispenser according to claim 12, wherein the command is a command to dispense a serving of the beverage into the serving receptacle.

15. A beverage dispenser according to claim 1, further comprising a temperature sensor configured to monitor the temperature of the bottle.

16. A beverage dispenser according to claim 1, further comprising:

a movable platform having a plurality of positions for a respective plurality of serving receptacles; and

a motor connected to the movable platform and configured to move the movable platform to position each of the plurality of serving receptacles into a position to accept a serving of the beverage poured from the bottle, and

wherein the controller is connected to the motor and further configured to move the movable platform to position each of the plurality of serving receptacles into a position to accept a serving of the beverage poured from the bottle.

17. A beverage dispenser according to claim **16**, wherein the movable platform is a turntable.

18. A method comprising:
mechanically accepting and holding a bottle containing a beverage; and

automatically controlling a motor for moving the bottle at a pivot point between the top and bottom of the bottle in an angular movement from a first position to a second position, wherein the first position is a position maintaining the beverage within the bottle, and the

second position is a pouring position to cause a predetermined quantity of the beverage by gravity to pour into a serving receptacle in which the predetermined quantity is determined by a preprogrammed angular movements over time.

19. A beverage pouring apparatus comprising:

means for accepting and holding a multi-serving bottle containing a beverage; and

means for controlling a motor automatically to move the bottle at a pivot point between the top and bottom of the bottle in an angular movement from a first position to a second position, wherein the first position is a position maintaining the beverage within the bottle, and the second position is a pouring position to cause a predetermined quantity, a serving, of the beverage by gravity to pour into a serving receptacle in which the predetermined quantity is determined by a preprogrammed angular movements over time.

* * * * *